

2NTPA-M

公制可分型锁紧螺母

Divisible locknut, metric

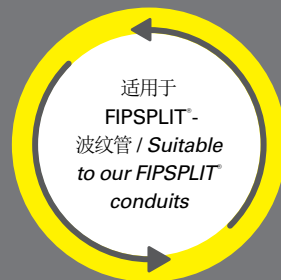
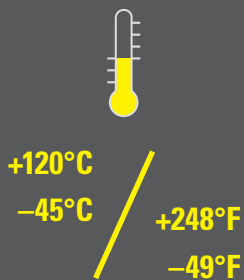

IP-防护等级 IP-Protection class

IP44

- └─ 防护泼水
Protected against splashing water
- └─ 防护直径 1 mm 以上的物质
Protected against solid objects over 1 mm

材料: PA6 MOD BS SGA

可分型锁紧螺母 2NTPA-M 由特殊改性尼龙6材料制成。适用于已经将线缆或线束安装好,但接头螺纹需要锁紧的场合。锁紧螺母可以安全的扣合并永久紧固。2NTPA-M 特别适用于可开式接头 2SPA-M 配 FIP SPLIT[®] 波纹管的场合。

Material: PA6 MOD BS SGA

The divisible locknut 2NTPA-M, made of specially formulated Polyamide 6, is suitable for retrofit applications in order to firmly tight threaded fittings applied to conduits where wires and cables are already installed. The locknut can be securely closed and permanently tightened. 2NTPA-M specially fits with the divisible fittings 2SPA-M used with FIP SPLIT[®] conduits.

2NTPA-M

产品性能 / Product performances

应用性能 / Application performances	特性 Characteristics	单位 Unit	规范标准 Standards, specifications	备注 Remark
温度范围 Temperature range	-45 到 / to +120 -49 到 / to +248	°C °F	IS FIP	
温度 (短周期) Temperature (short-term)	+140 + 284	°C °F	IS FIP	
防火性能 / Fire safety performances				
不含卤素和镉 Free from halogens and cadmium	是 / yes			
阻燃等级 Fire classification	V2		UL 94	
灼热丝测试 Glow wire test	850 1562	°C °F	EN60695-2-10	
氧指数 Oxygen index	>28	%	EN ISO 4589-2	
系统防护性能 / System performances				
IP 等级 Ingress protection (IP)	IP44		EN60529	

测试条件参照EN ISO 139温度23°C, 湿度 / 50% (如未注明测试条件)。IS FIP = FIP内部测试规范。
 Tests carried out acc. EN ISO 139 at 23°C/50% r. h. (if not indicated different). IS FIP = Internal Specification FIP

产品号 Part No.		名义尺寸 Nominal width	螺纹尺寸 Thread size	尺寸 (mm) Dimensions in mm (nom.)			包装单元 PU
黑色 / black	灰色 / grey	NW	公制 / metric	SW	C	E	m
2NTPA-10M16PB	2NTPA-10M16PG	10	M16	19,0	8,0	21,0	10
2NTPA-14M20PB	2NTPA-14M20PG	14	M20	27,0	8,0	29,0	10
2NTPA-20M25PB	2NTPA-20M25PG	20	M25	32,0	9,0	35,0	10
2NTPA-23M32PB	2NTPA-23M32PG	23	M32	40,0	12,0	44,0	10
2NTPA-37M40PB	2NTPA-37M40PG	37	M40	48,0	15,0	53,0	10
2NTPA-45M50PB	2NTPA-45M50PG	45	M50	64,0	15,0	69,0	10

关于产品库存, 交期, 尺寸及颜色等问题请联系我们本地的经销商或客服。

Please contact our local distribution partner or our customer service regarding product availability, lead time, other sizes and colours.

产品代码 / Number code:

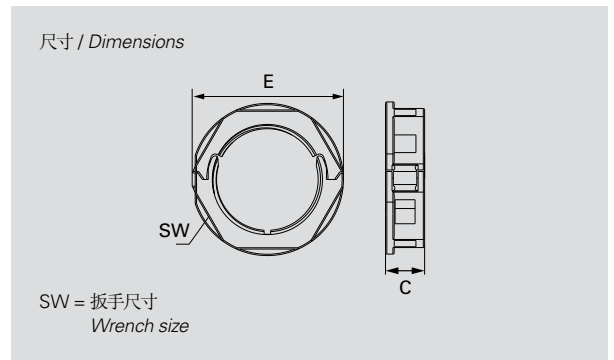
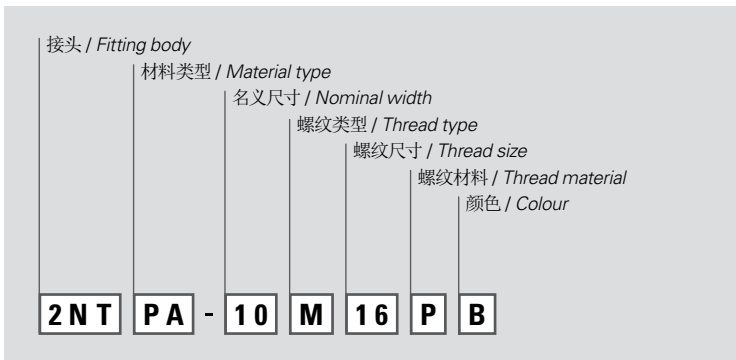

我们尽我们的知识水平所提供的数据, 图像和技术规格图反映了当前的工程技术水平。这并不包含对最后应用有关的任何责任。产品用户需根据应用进行自己的评估, 以确定产品是否符合特殊的应用条件。我们对产品的责任只考虑一般规定条件下的水平。FIP保留对产品数据和数值进行技术调整的权力。例如更改材料和加工工艺, 在保证产品性能数值不下降的情况下不会另行通知。

The provided data, images and technical specification drawings reflect the current engineering level and are to the best of our knowledge. This does not include any liability regarding the final application. Users of the products have to make their own evaluation to determine the suitability for a specific application. Our liability for these products considers the stated level within our General Conditions only. FRAENKISCHE Industrial Pipes (FIP) reserves the right to adjust specified data and values as well as implementing technical adjustments of the products e. g. change of materials and processing technologies without prior notice as long as the specified values are not reduced.