

安装说明FIPSHIELD® 带铜刷的EMC锁紧螺母

Assembly instruction FIPSHIELD® locknut with EMC contact BRUSH

安装 / Assembly

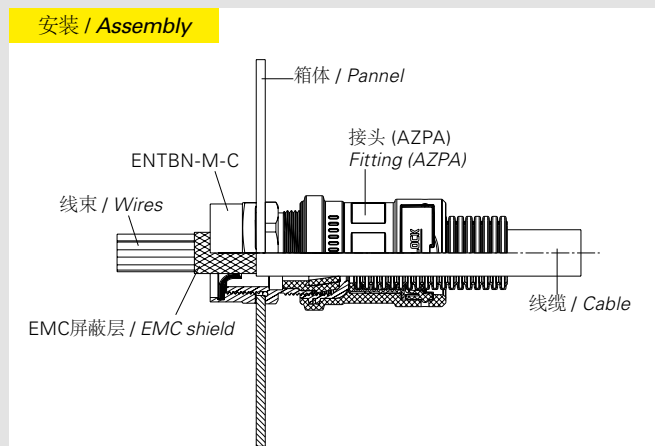

线缆准备 / Preparing of the cable

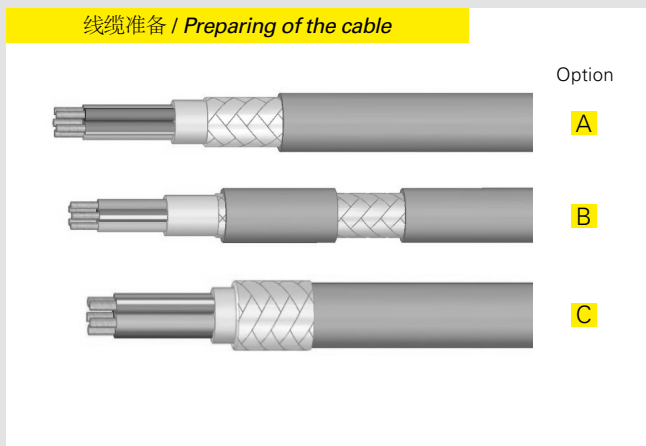

1. 将FIPSHIELD® ENTBN-M-C拧入接头/葛兰头直到接触到箱体。

Screw FIPSHIELD® ENTBN-M-C on fitting/gland thread until contact with pannel consists.

2. 安装线缆 (线缆屏蔽段安装在铜刷接触点位置)。

Apply cable (dismantled in the contact area).

3. 锁紧。

Tighten cap nut.

- A 从线缆端部剥离外皮露出屏蔽层。

Remove the cable sheath from the end section of screen braiding.

- B 从线缆中部剥离一段外皮露出屏蔽层。

Remove a segment of cable sheath at the contact area.

- C 将屏蔽层翻起拉到线缆外皮上。

Pull the fringed section of screen braiding over the cable sheath.

技术表 / Technical table:

螺纹尺寸 / Thread	ENTBN-M-C锁紧扭力 / Tightening torque for ENTBN-M-C	
	塑料螺纹接头最大安装扭矩 for plastic thread fitting	金属螺纹接头最大安装扭矩 for metal thread fitting/gland
M12x1,5mm	2 Nm	8 Nm
M16x1,5mm	4 Nm	10 Nm
M20x1,5mm	6 Nm	12 Nm
M25x1,5mm	8 Nm	12 Nm
M32x1,5mm	10 Nm	18 Nm
M40x1,5mm	12 Nm	18 Nm
M50x1,5mm	13 Nm	20 Nm
M63x1,5mm	13 Nm	20 Nm

温度范围 / Temperature range:

ENTBN-M-C: -70°C 到 + 200°C / -70°C up to 200°C

注意 / Note:

铜刷仅用于EMC电磁屏蔽的目的。它不能用于电位平衡。

The BRUSH is to be used only for EMC purposes. It is strictly forbidden to use the BRUSH as a potential equalisation.